

JUXTA F Series General Specification

FX1□-DV (Variable software type)
Divider

JUXTA

1. GENERAL

This is a variable software type computing unit which accepts two voltage signal inputs from various converters and outputs an isolated DC voltage or current signal after 2-input division are performed.

2. SPECIFICATIONS

Model No.	FX1A-DV, FX1V-DV
Input signal	DC voltage signal: 2 points V ₀ to V ₁₀₀ correspond to 0 to 100%.
Measuring range	0 to 10 V DC (Measuring span: More than 2 V) (*1)
Input resistance	1 MΩ (At power failure: More than 100 KΩ)
Output signal	4 to 20mA, 2 to 10mA, 1 to 5mA, 0 to 20mA, 0 to 16mA, 0 to 10mA or 0 to 1mA DC 0 to 10mV, 0 to 100mV, 0 to 1V, 0 to 10V, 0 to 5V, 1 to 5V or -10 to +10V DC
Computing equation	$Y = \frac{K3(K1 \cdot X1 + A1)}{K2 \cdot X2 + A2} + A3$ Where, Y: Output signal (%) X1 and X2: Input signal (%) K1 to K3: Gain (No unit) (*2) A1 to A3: Bias (%) (*3)
Gain/bias setting range	Gain: ±7.990 and bias: ±799.0% Both correspond to ±799.0%. Determine the ranges so that the computing and the computed values do not exceed ±800.0%.
Basic accuracy	±0.3% of measuring span
Signal insulation	Between input signal and output signal/power supply circuits, and between output signal and power supply circuits
Insulation resistance	Between input signal and output signal/power supply circuits and Between output signal and power supply circuits: 100 MΩ/500 V DC
Dielectric strength	Between input signal and output signal/power supply circuits: 1500 V AC/min. Between output signal and power supply circuits: 500 V AC/min
Power supply voltage	24 V DC ± 10%
Ambient temperature/humidity	0 to 50°C (32 to 122°F) and 5 to 93% relative humidity (No condensation)
Effect of ambient temperature	±0.2% of span for 10°C (50°F) change
Effect of power supply voltage	±0.1% of span for 24 V DC ±10% variation
Power consumption	24 V DC, 60 mA (Voltage output) and 24 V DC, 82 mA (Current output)
Dimensions	72 (2.83") H × 24 (0.94") W × 127 (5.00") D mm (inch)
Weight	Approx. 130 g
Accessories	Tag number label : 1 sheet Mounting blocks: 2 pcs.

Specify the following when ordering:

(*1) Measuring range from □ to □ V

(*2) Gain K1, K2 and K3 within the range between -7.990 and 7.990

(*3) Biases A1, A2 and A3 within the range between -799.0 and 799.0%

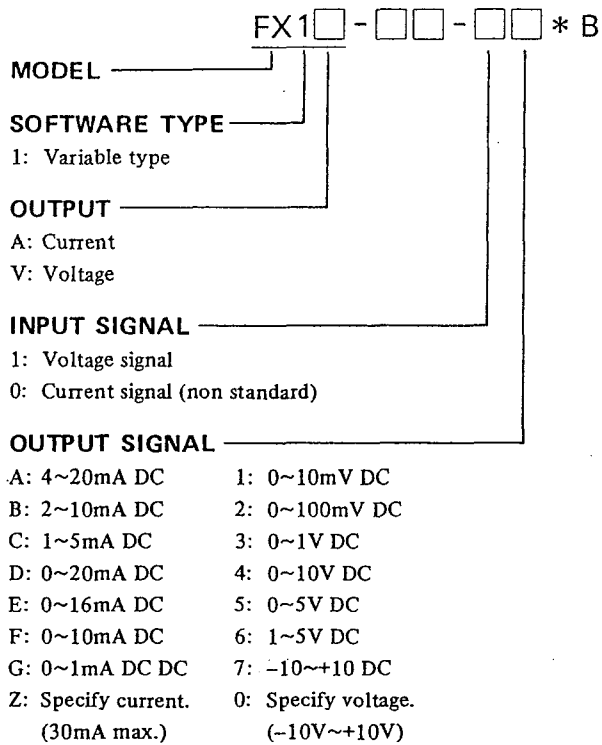

Ordering Information

Measuring Range of Input	
Voltage input signal: 2V min. Span for 0~10V DC Current input signal (input resist. 250Ω): (250Ω) × (Input current) shall be within the measuring span of voltage input signal.	
	Recommended Range
Current signal	4~20mA DC 2~10mA DC 0~20mA DC 0~16mA DC 0~10mA DC
Voltage signal	0~10V DC 0~ 5V DC 1~ 5V DC

(Note) Change of input between voltage and current is impossible by Handy Terminal.

OUTPUT RESISTANCE AND LOAD RESISTANCE

Output Signal	Load Resistance	Output Impedance
4 to 20mA DC	0 to 750Ω	5MΩ or more
2 to 10mA DC	0 to 1500Ω	
1 to 5mA DC	0 to 3000Ω	
0 to 20mA DC	0 to 750Ω	
0 to 16mA DC	0 to 900Ω	
0 to 10mA DC	0 to 1500Ω	
0 to 1mA DC	0 to 15kΩ	

Output Signal	Load Resistance	Output Impedance
0 to 10mV DC	100kΩ or more	100Ω or less
0 to 100mV DC		
0 to 1V DC	2kΩ or more	1Ω or less
0 to 5V DC		
1 to 5V DC		
0 to 10V DC	10kΩ or more	
-10 to +10V DC		

Subject to change without notice for grade up quality and performance